

## 4. RAJD GRODZKI

### 4 RUNDA RAJDOWYCH SAMOCODOWYCH MISTRZOSTW PODKARPACIA 5 RUNDA RAJDOWYCH SAMOCHODOWYCH MISTRZOSTW ŚLĄSKA

Data:	<b>05.10.2018</b>	Godzina:	<b>19:30</b>
Temat:	<b>Komunikat Nr 2</b>	Doc. Nr	<b>1.2</b>
Od:	<b>Dyrektora Rajdu</b>	Stron:	<b>4</b>
Do:	<b>Wszystkich zawodników</b>	Zał.:	<b>0</b>

1. Wprowadza się zmiany w pkt. 11.6.2. Regulaminie Uzupełniającym:  
**BYŁO:** Skrócona kontrola wyposażenia samochodu oraz bezpieczeństwa osobistego załogi odbędzie się w dniu startu do rajdu 15 września 2018r., przed PKC – 0, wyjazd z parku serwisowego.

**JEST:** Skrócona kontrola wyposażenia samochodu oraz bezpieczeństwa osobistego załogi odbędzie się w dniu startu do rajdu 7 października 2018r., przed PKC – 0, wyjazd z parku serwisowego.

2. Wprowadza się zmiany w Księżce Drogowej:

#### A. Trasa dojazdu z BIURA RAJDU do STARTU HONOROWEGO – RYNEK GORLICE

**BYŁO:**

BIURO RAJDU		START HONOROWY - RYNEK GORLICE		Distance	1,87 km	Leg
Special Stage				Average speed	*****	Section
				Time allowed		Time allowed
Distance	Direction	Information				Dist. to go
Total	Partial					Dist. to go
0,00	---			Wyjazd z Serwisu		1,87
		1				
0,49	0,49					1,38
		2				
1,14	0,65					0,73
		3				
1,35	0,21					0,52
		4		ul. Hugona Koliątaja		
1,67	0,32					0,20
		5		ul. Narutowicza		

0,08 → EMERGENCY NUMBER (+48) 601-100-777 PAGE 12

BIURO RAJDU		START HONOROWY - RYNEK GORLICE		Distance	1,87 km	Leg
Special Stage				Average speed	*****	Section
				Time allowed		Time allowed
Distance	Direction	Information				Dist. to go
Total	Partial					Dist. to go
1,75	0,08					0,12
		6				
1,87	0,12					0,00
		7		ul. 3 maja		

EMERGENCY NUMBER (+48) 601-100-777 PAGE 13

**JEST:**

Distance		Direction		Information	Dist. to go
Total	Partial				
0.00	---			Wyjazd z Serwisu	1,44
0.49	0,49			 	0,95
1.09	0,60				0,35
1.44	0,35			START HONOROWY	0.00

EMERGENCY NUMBER (+48) 601-100-777

PAGE 12

**B. Trasa dojazdowa do TC 1/3/5 – ROPA**

**BYŁO:**



4,41	2,52				11,67
5,09	0,68				10,99

**JEST:**



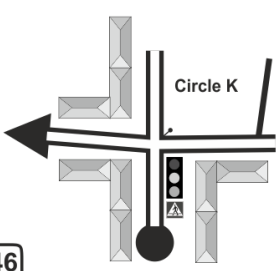
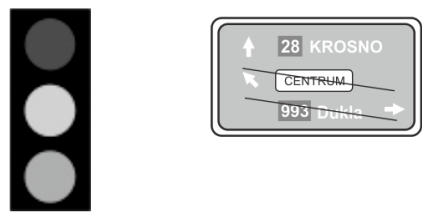
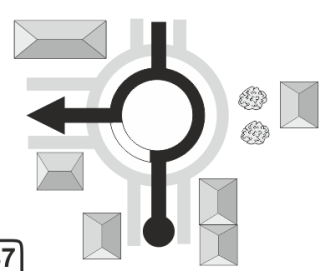
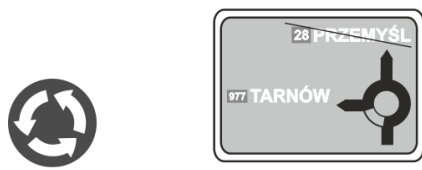
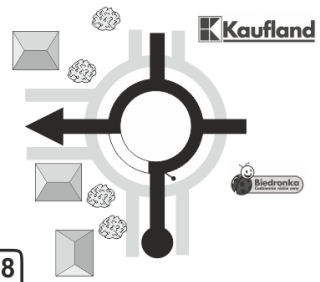
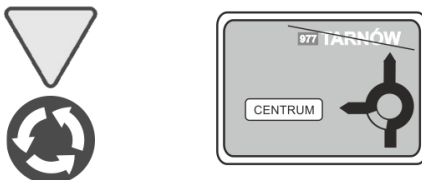
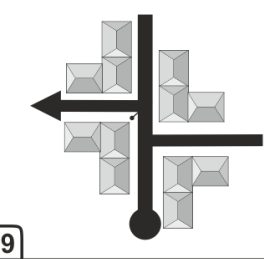
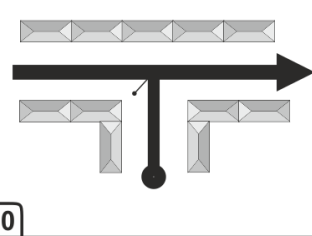
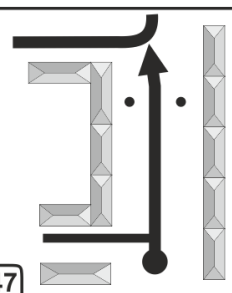

4,41	2,52				11,67
5,09	0,68				10,99

### C. Trasa dojazdowa do TC 6A – META Rynek Gorlice

**BYŁO:**

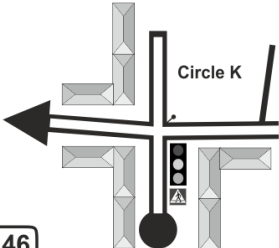
Total	Partial			
28,41	0,23	 <p>46</p>		1,38
29,06	0,65	 <p>47</p>		0,73
29,27	0,21	 <p>48</p>	 ul. Hugona Kołłątaja	0,52
29,59	0,32	 <p>49</p>	ul. Narutowicza	0,20
29,67	0,08	 <p>50</p>	ul. 3 maja	0,12
Distance		Information		Dist. to go
Total	Partial	 <p>47</p>	 ul. 3 maja	0,00

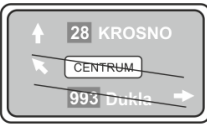
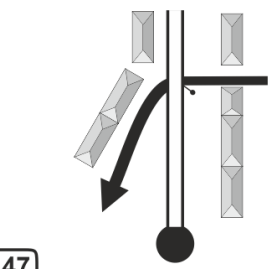
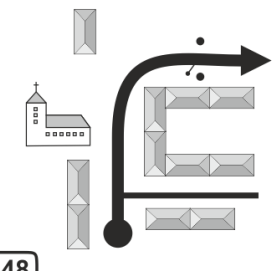
**JEST:**

28,56	0,38	 46	 	1,23
29,16	0,60	 47		0,63
29,79	0,63	 48	 PKC 6A	0,00

*Mateusz Kacprzak*  
**Dyrektor Rajdu**  
**Mateusz Kacprzak**

**Zatwierdzono:**  
**Okręgowa Komisja Sportu Samochodowego**  
**Polskiego Związku Motorowego w Rzeszowie**  
**Przewodniczący – Andrzej Makaran**